

Digital Flow and Volume Register (DFV)

Liquip are proud to announce the release of the Digital Flow and Volume Series of Register and Diptronic Controller.

The latest advancements in Liquip’s electronics has allowed Liquip to develop the fully safety approved DFV to function as a standalone electronic register, Diptronic CPU or combined unit.

All potted versions of the DFV series are approved for use in Zone 1 (IECEx and ATEX) applications and the DFV series holds a range of meteorological approvals for geographical locations including Australian NMI, New Zealand Weights & Measures and European (MID) with other approvals pending.

With a range of models available and combining the best in performance, style and functionality, the DFV is the right choice for Register and Diptronic applications.



	DFV102 ^T	DFV100	DFV103	DFV101
Register	✓	✓	✗	✓
Diptronic	✗	✗	✓	✓
Updateable*	✓	✓	✓	✓
Upgradeable**	✗	✓	✓	N/A
Operating Temperature	-20°C to +60°C	-20°C to +60°C	-20°C to +60°C	-20°C to +60°C
IP rating	IP66	IP66	IP66	IP66

SAFETY APPROVALS

	DFV102	DFV100	DFV103	DFV101
Suitable for: Zone 2 IEC Ex	✓	✓	✓	✓
Zone 1 IEC Ex	✗	✓	✓	✓
Zone 1 ATEX	✗	✓	✓	✓
Class 1 Div 1 ULus, cUL	✗	PENDING	PENDING	PENDING

METROLOGICAL APPROVALS

	DFV102	DFV100	DFV103	DFV101
AUST W&M	✓	✓	✓	✓
NZ W&M	✓	✓	✓	✓
MID - OIML (EU)	✓	✓	PENDING	N/A
NTEP	✗	PENDING	N/A	PENDING
Measurement Canada	✗	PENDING	PENDING	PENDING

^T Limited stock available. Once stock is consumed, please order DFV100.

* Updateable: Free software updates are available as issued by Liquip.

** Upgradeable: Chargeable upgrades are available to convert a DFV100 or DFV103 to a DFV101.



DFV100 Electronic Register

The DFV100 series is the latest advancement in Liquip's range of electronics, featuring as a stand alone register, Diptronic CPU or combined unit.

The DFV100 series provides reliable and accurate service combined with long service life and simple operation.

The DFV100 is approved for use in Zone 1 (IECEx) truck mounted or fixed site product transfer applications.



Key Features

Common to all potted DFV units

- Safety Approved for use in Zone 1 (IECEx)
Ex e ib mb [ia] IIA T4 Gb IP66 (Ta = -20°C to +60°C)
- Safety Approved for use in Zone 1 (ATEX)
DEMKO 14 ATEX 1407X
Ex e ib mb [ia Ga] IIA T4 Gb IP66
Ta= -20°C to +60°C
CE 0518  II 2 (1) G
- Weights & Measures Approved: NMI-Australia, Europe-MID, New Zealand.
- Durable Aluminium housing with hinged door to allow easy access to internal connections.
- Large display to easily view multiple information simultaneously.
- RS232 and CAN communication.
- Intuitive set up and programming.
- Electronic calibration.
- Non-linearity correction.
- Non volatile memory for storing set parameters.
- Operates on 12 or 24 volt installations.
- Backlit display for ease of reading in low light.
- Piezoelectric buttons for reliability.

Associated Equipment

- Expansion modules - Contact Liquip
- Cold Climate Register - Contact Liquip
- ERP200 - Remote Pulser
- DFV101-UP - DFV100 Series upgrade to DFV101
- DFV103 - DFV Diptronic CPU
- DFV101 - DFV Register / Diptronic CPU
- 4155 - Temperature Probe

Register

- Connection to a ticket printer or a third party fuel management system.
- Can be connected to a large digit display.
- Micro SD card for easy software upgrades.
- Preset functionality / batch control.
- Solenoid outputs are voltage free and can perform a 2 stage ramp up and ramp down of the fluid flow.
- No flow timer.
- One calibration point with Weights & Measures sealable captive fastener.
- Compatible with most flow meters on the market.
- Pulse output can be programed as optional additional fourth relay.
- Functionally backwards compatible with Liquip EMH registers.
- Flowrate displayed on main screen along with volume during delivery.
- Future expansion and modularity available.
- DFV100 can be upgraded to include a Diptronic CPU - See DFV101 Datasheet.



Technical Information

Size	Approx, 250 x 200 x 140mm
Displays	1 line x 14 characters 14 mm high and 4 lines x 24 characters 8 mm high
Power Input	9 to 32Vdc (safety approved) or 9 to 45V (operational) @ 250mA polarity protected. External in-line fuse (rated 1.8A, antisurge) is a mandatory condition of safe use.
Operating Temperature	-20°C to +60°C
Temperature Correction	-40 to +60°C for all petroleum products Extended ranges available according to local regulations
Temperature Probe	Pt100 class A, 3 wires, Liquip P/N 4155
Ingress Protection	IP66
Product Density	0.500 - 0.600kg/L for LPG, 0.653 - 1.075kg/L for other products
Weight	4.6kg
Communication	Two RS232C ports to be used to communicate with a PC or other serial device such as a modem or printer. One CAN port.
Touch PC	Software is written for Touch-PC on-line communication. Commands that can be interrogated include resetting the meter and requesting the current delivery quantity.
Printer	Epson CTM-290 or TM-295, Blaster Printer.
Pulse Input	Will accept 3-channel pulses of 60° phase shifted, from ERP200 pulser, dual (quadrature) or single pulse (reed or open-collector) from third-party pulsers. Third party pulsers may not be NMI approved
Pulse Output	Open drain, active-low output, signal calibrated to 10 pulses/litre, where the pulse frequency can be set up to either 400Hz or 2kHz max. (with fixed pulse duration 1.25 ms or 0.25 ms respectively). Additional in-line fuse (2A, antisurge) is a mandatory condition of safe use.
Pulse/External Reset	This is an input/output signal. Additional in-line fuse (2A, antisurge) is a mandatory condition of safe use.
Relay Outputs	Up to 4 Relay Outputs. Current sink, 2A max. Solenoid to be connected between this output and the positive of the power supply. Additional in-line fuse (2A, antisurge) is a mandatory condition of safe use.
Program Memory	microSD card

Mounting Instructions

The DFV100 can be either remote mounted or mounted to a meter using an adaptor bracket.

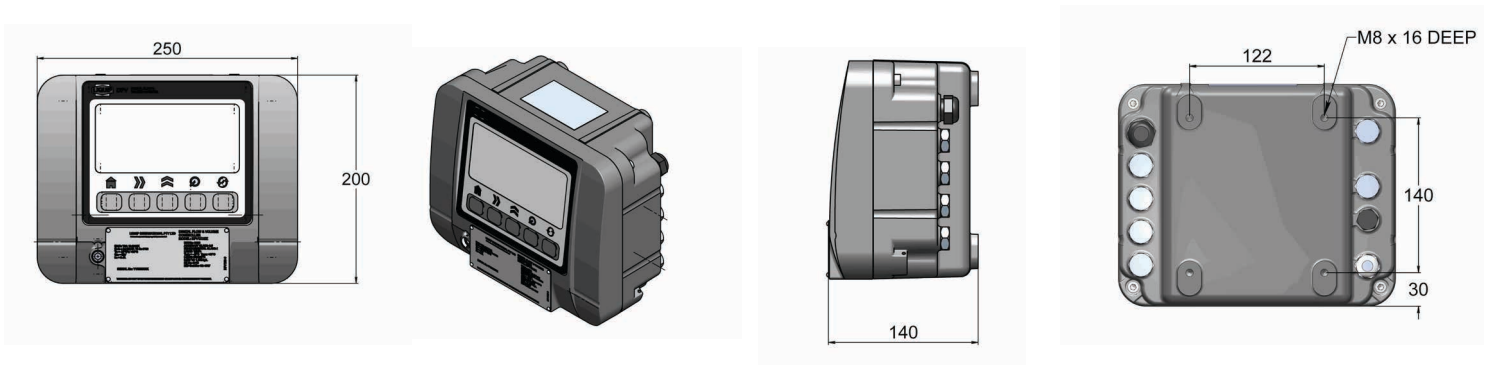

Adaptor Bracket: Front mount to various meters

When direct mounting to a meter is unavoidable
DFV100-23 (Suits the following meters)

- LC - M5, M7, M10, M15, M25, M30, M40, M60
- SAMPI - M5, M7, M15, M30

Adaptor Bracket: Top mount to various meters

DFV100-18 - Top mount bracket to suit meters that use the OE standard 4 bolt register mount.

For mounting to other meters please contact Liquip

DFV101 Combined Register and Diptronic

The DFV100 series is the latest advancement in Liquip's range of electronics, featuring as a stand alone register or Diptronic CPU.

The DFV101 is a state of the art electronic meter register and level gauging monitor in one compact housing.

The DFV101 allows for increased operational efficiency through a lightweight design and by combining two units into one, users will be able to achieve the benefits of both units by ordering a single unit.

The DFV101 is approved for Zone 1 (IECEX) truck mounted or fixed site product transfer applications..



Key Features

Common to all potted DFV units

- Safety Approved for use in Zone 1 (IECEX). IECEX TSA 14.0021X Ex e ib mb [ia] IIA T4 Gb IP66 (Ta = -20°C to +60°C)
- Safety Approved for use in Zone 1 (ATEX) DEMKO 14 ATEX 1407X Ex e ib mb [ia Ga] IIA T4 Gb IP66 (Ta= -20°C to +60°C) C€ 0518 II 2 (1) G
- Weights & Measures Approved: NMI-Australia & New Zealand.
- Durable Aluminium housing with hinged door to allow easy access to internal connections.
- Large display to easily view multiple information simultaneously.
- RS232 and CAN communication.
- Intuitive set up and programming.
- Electronic calibration.
- Non-linearity correction.
- Non volatile memory for storing set parameters.
- Operates on 12 or 24 volt installations.
- Backlit display for ease of reading in low light.
- Piezoelectric buttons for reliability.
- Connection to a ticket printer or a third party fuel management system.
- Can be connected to a large digit display.
- Micro SD card for easy software upgrades.

Register

- Preset functionality / batch control.
- Solenoid outputs are voltage free and can perform a 2 stage ramp up and ramp down of the fluid flow.
- No flow timer.
- One calibration point with Weights & Measures sealable captive fastener.
- Compatible with most flow meters on the market.
- Pulse output can be programed as optional additional fourth relay.
- Functionally backwards compatible with Liquip EMH registers.
- Flowrate displayed on main screen along with volume during delivery.
- Future expansion and modularity available.

Diptronic

- Automatic level gauging updated in real time keeps users off the top of the tank.
- Same menu system as DIP200 for ease of operation with operators already familiar with Liquip Diptronic.
- CAN output for rapid communication with external device.
- Can read up to 9 probes/compartments.
- Can be used to provide a sealed parcel solution.
- DFV103 comes with built in power filter negating the need for external power filter.
- Can be connected to slave unit to read an additional 6 probes/compartments.
- Volume shown in 1L increments.
- ±1mm accuracy with no moving parts for minimal maintenance.
- Enables temperature compensated deliveries.
- Enables split deliveries to maximise fleet efficiency.

Associated Equipment

- ERP200 - Remote Pulser
- 4155 - Temperature Probe
- DFV100 - DFV Register
- DFV103 - DFV Diptronic CPU
- DIP130 - Diptronic Stick
- DIP150 - Diptronic Stick - Low Profile
- Expansion Modules - Contact Liquip
- Cold climate register - Contact Liquip

Technical Information

Size	Approx, 250 x 200 x 140mm
Displays	1 line x 14 characters 14 mm high and 4 lines x 24 characters 8 mm high
Power Input	9 to 32Vdc (safety approved) or 9 to 45V (operational) @ 250mA polarity protected. In-line fuse (rated 3A, antisurge) is strongly recommended
Operating Temperature	-20°C to +60°C (safety approved)
Temperature Correction	-40 to +60°C for all petroleum products Extended ranges available according to local regulations
Temperature Probe	Pt100 class A, 3 wires, Liquip P/N 4155
Ingress Protection	IP66
Product Density	0.653 - 1.075kg/L (petroleum products) - For others contact Liquip
Weight	Approx. 6kg
Communication	Two RS232C ports to be used to communicate with a PC or other serial device such as a modem or printer. One CAN port. Compatible with Epson CTM-290 or TM-295, Blaster Printer.
Touch PC	Commands that can be interrogated include resetting the meter and requesting the current delivery quantity. See software section for detail.
Pulse Input	Will accept 3-channel pulses of 60° phase shifted, from ERP200 pulser, dual (quadrature) or single pulse (reed or open-collector) from third-party pulsers. Third party pulsers may not be NMI approved
Pulse Output	Open drain, active-low output, signal calibrated to 10 pulses/litre, where the pulse frequency can be set up to either 400Hz or 2kHz max. (with fixed pulse duration 1.25 ms or 0.25 ms respectively).
External Reset	This is an input/output signal.
Relay Outputs	Up to 4 Relay Outputs. Current sink, 3A max. Solenoid to be connected between this output and the positive of the power supply. Additional in-line fuse (3A, antisurge) is strongly recommended.
Program Memory	microSD card

Mounting Instructions

The DFV101 can be either remote mounted or mounted to a meter using an adaptor bracket.

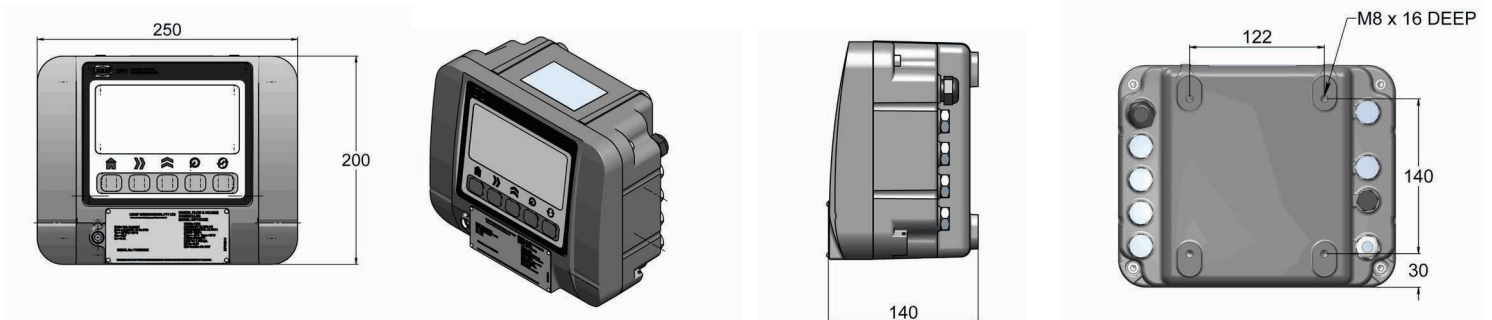

Adaptor Bracket: Front mount to various meters

When direct mounting to a meter is unavoidable

DFV100-23 (Suits the following meters)

- LC - M5, M7, M10, M15, M25, M30, M40, M60
- SAMPI - M5, M7, M15, M30

Adaptor Bracket: Top mount to various meters

DFV100-18 - Top mount bracket to suit meters that use the OE standard 4 bolt register mount.

For mounting to other meters please contact Liquip

DFV102 Electronic Register

The DFV102 is the latest in Liquip's range of electronic registers. It replaces the EMH500H and EMH600RP.

The DFV provides reliable and accurate service combined with easy operation.

This register is approved for Zone 2 (IECEx) truck mounted or fixed site product transfer applications.



Key Features

- Safety Approved for use in Zone 2 (IECEx).
- Weights & Measures Approved: NMI-Australia, Europe-MID, New Zealand.
- Connection to a ticket printer or a third party fuel management system.
- Large display to easily view multiple information simultaneously.
- Electronic calibration.
- Non-linearity correction.
- Non volatile memory for storing set parameters.
- Operates on 12 or 24 volt installations.
- Backlit display for ease of reading in low light.
- Intuitive set up and programming.
- Piezoelectric buttons for reliability.
- Micro SD card for easy software updates.
- Preset functionality / batch control.
- Solenoid outputs are voltage free and can perform a 2 stage ramp up and ramp down of the fluid flow.
- Pulse output can be programmed as optional additional relay.
- Durable Aluminium housing with hinged door to allow easy access to internal connections.
- RS232 and CAN communication.
- One calibration point with Weights & Measures sealable captive fastener.
- Functionally backwards compatible with Liquip EMH registers.
- Flowrate displayed on main screen along with volume during delivery.

Associated Equipment

- ERP200 Remote Pulser



Technical Information

Size	Approx, 245 x 200 x 140mm
Displays	1 line x 14 characters 14 mm high and 4 lines x 24 characters 8 mm high
Power Input	9 to 32Vdc (safety approved) or 9 to 45V (operational) @ 250mA polarity protected. External in-line fuse (rated 1.8A, antisurge) is a mandatory condition of safe use.
Operating Temperature	-20°C to +60°C
Temperature Correction	-40 to +60°C for all petroleum products Extended ranges available according to local regulations
Temperature Probe	Pt100 class A, 3 wires, Liquip P/N 4155
Ingress Protection	IP66
Product Density	0.500 - 0.600kg/L for LPG, 0.653 - 1.075kg/L for other products
Weight	4.6kg
Communication	Two RS232C ports to be used to communicate with a PC or other serial device such as a modem or printer. One CAN port. Compatible with Epson CTM-290 or TM-295, Blaster Printer.
Touch PC	Software is written for Touch-PC on-line communication. Commands that can be interrogated include resetting the meter and requesting the current delivery quantity.
Pulse Input	Will accept 3-channel pulses of 60° phase shifted, from ERP200 pulser, dual (quadrature) or single pulse (reed or open-collector) from third-party pulsers. Third party pulsers may not be NMI approved
Pulse Output	Open drain, active-low output, signal calibrated to 10 pulses/litre, where the pulse frequency can be set up to either 400Hz or 2kHz max. (with fixed pulse duration 1.25 ms or 0.25 ms respectively). Additional in-line fuse (2A, antisurge) is a mandatory condition of safe use.
Pulse/External Reset	This is an input/output signal. Additional in-line fuse (2A, antisurge) is a mandatory condition of safe use.
Relay Outputs	Up to 4 Relay Outputs. Current sink, 2A max. Solenoid to be connected between this output and the positive of the power supply. Additional in-line fuse (2A, antisurge) is a mandatory condition of safe use.
Program Memory	microSD card

Mounting Instructions

The DFV102 can be either remote mounted or mounted to a meter using an adaptor bracket.

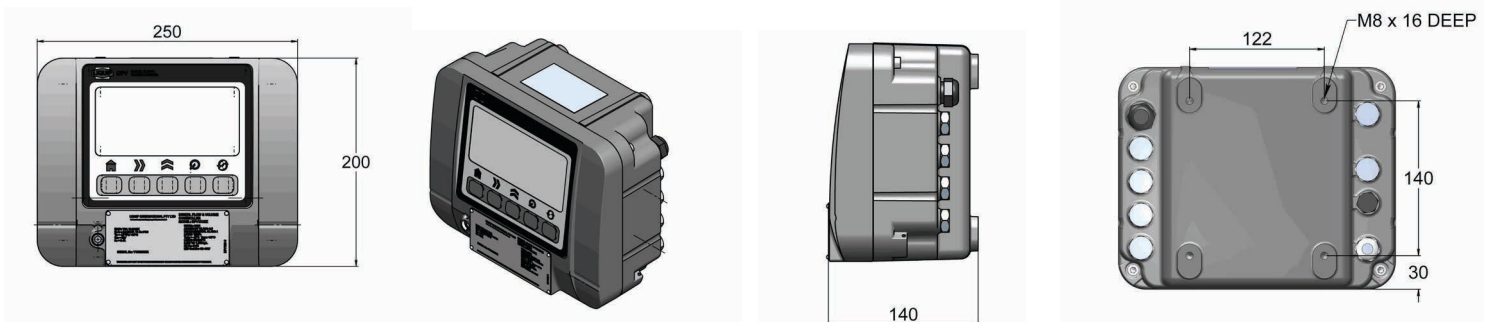

Adaptor Bracket: Front mount to various meters

When direct mounting to a meter is unavoidable

DFV100-23 (Suits the following meters)

- LC - M5, M7, M10, M15, M25, M30, M40, M60
- SAMPI - M5, M7, M15, M30

Adaptor Bracket: Top mount to various meters

DFV100-18 - Top mount bracket to suit meters that use the OE standard 4 bolt register mount.

For mounting to other meters please contact Liquip

DFV103 Diptronic Level Gauge Monitor

The DFV100 series is the latest advancement in Liquip's range of electronics, featuring as a stand alone register, Diptronic CPU or combined unit.

When you require safe, accurate and fast level gauging there is the DFV103 CPU. The DFV103 measures liquid levels in road and static tanks. Suitable for use in many industries and applications including petroleum, chemical, aviation and waste.

The DFV103 is approved for Zone 1 (IECEX) applications.

Key Features

Common to all potted DFV units

- Safety Approved for use in Zone 1 (IECEX)
IECEX TSA 14.0021X
Ex e ib mb [ia] IIA T4 Gb IP66 (Ta = -20°C to +60°C)
- Safety Approved for use in Zone 1 (ATEX)
DEMKO 14 ATEX 1407X
Ex e ib mb [ia Ga] IIA T4 Gb IP66 (Ta = -20°C to +60°C)
CE 0518 II 2 (1) G
- Weights & Measures Approved: NMI-Australia & New Zealand.
- Durable Aluminium housing with hinged door to allow easy access to internal connections.
- Large display to easily view multiple information simultaneously.
- RS232 and CAN communication.
- Intuitive set up and programming.
- Electronic calibration.
- Non-linearity correction.
- Non volatile memory for storing set parameters.
- Operates on 12 or 24 volt installations.
- Backlit display for ease of reading in low light.
- Piezoelectric buttons for reliability.
- Connection to a ticket printer or a third party fuel management system.
- Can be connected to a large digit display.
- Micro SD card for easy software upgrades.

Associated Equipment

- DFV101-UP - DFV100 Series upgrade to DFV101
- DFV100 - DFV Register
- DFV101 - DFV Register / Diptronic CPU
- DIP130 - Diptronic Stick
- DIP150 - Diptronic Stick - Low Profile
- Expansion modules - Contact Liquip



Diptronic

- Automatic level gauging updated in real time keeps users off the top of the tank.
- Same menu system as DIP200 for ease of operation with operators already familiar with Liquip Diptronic.
- CAN output for rapid communication with external device.
- Can read up to 9 probes/compartments.
- Can be used to provide a sealed parcel solution.
- DFV103 comes with built in power filter negating the need for external power filter.
- Can be connected to slave unit to read an additional 6 probes/ compartments.
- Volume shown in 1L increments.
- ±1mm accuracy with no moving parts for minimal maintenance.
- Enables temperature compensated deliveries.
- Enables split deliveries to maximise fleet efficiency.
- Unit can be upgraded to combine electronic register - See DVF101 datasheet.

Technical Information

Size	Approx, 250 x 200 x 140mm
Displays	1 line x 14 characters 14 mm high and 4 lines x 24 characters 8 mm high
Power Input	9 to 32Vdc (safety approved) or 9 to 45V (operational) @ 250mA polarity protected. External in-line fuse (rated 1.8A, antisurge) is a mandatory condition of safe use.
Operating Temperature	-20°C to +60°C
Temperature Correction	-40 to +60°C for all petroleum products Extended ranges available according to local regulations
Temperature Probe	Pt100 class A, 3 wires, Liquip P/N 4155
Ingress Protection	IP66
Product Density	0.500 - 0.600kg/L for LPG, 0.653 - 1.075kg/L for other products
Weight	4.6kg
Communication	Two RS232C ports to be used to communicate with a PC or other serial device such as a modem or printer. One CAN port.
Printer	Epson CTM-290 or TM-295, Blaster Printer.
Relay Outputs	Up to 4 Relay Outputs. Current sink, 2A max. Solenoid to be connected between this output and the positive of the power supply. Additional in-line fuse (2A, antisurge) is a mandatory condition of safe use.
Program Memory	microSD card

Mounting Instructions

The DFV103 should be mounted using a bracket to suit the below dimensions.

